

ECAN 7016



- Field Bus data acquisition
 - CAN open protocol
- Baud rate and ID Node programmable by dip-switch
 - Configurable input for mV and TC
 - Three ways 2000 Vac galvanic isolation
 - EMC compliance – CE Mark
- In compliance with EN-50022 DIN rail mounting

Index

1.0 General description	1
1.1 Communication protocols.....	1
1.2 Operating instructions.....	1
2.0 Technical specifications	2
2.1 Installation instructions.....	3
2.2 Cabling.....	3
2.3 Wiring.....	4
2.3.1 CAN network wiring and power supply wiring.....	4
2.3.2 Input wiring.....	4
2.4 DIP – SWITCH.....	5
2.4.1 DIP-SWITCH position.....	5
2.4.2 DIP-SWITCH configuration tables.....	5
2.5 LED signalling.....	6
2.6 Mechanical dimensions (mm).....	6
3.0 Profile description	7
4.0 DIP-SWITCH configuration	7
5.0 The object dictionary (OD)	8
6.0 Process data Object (PDO)	8
6.1 COB-ID.....	9
6.2 Transmission type.....	9
6.3 Inhibit time.....	10
6.4 Event Timer.....	10
7.0 Functional diagram for analogue inputs transmission	11
7.1 Interrupt triggering TPDO transmission.....	11
8.0 Set the operative state at the device's startup	12
8.1 "Operational" state setting.....	12
8.2 "Pre-Operational" state setting.....	12
9.0 Object dictionary (OD)	13

1.0 General description

The device ECAN 7016 is able to acquire up to 4 Thermocouple or mV inputs. The data are transmitted by the CANopen protocol.

By means of 16 bit converters, the device guarantees high accuracy and a stable measures both versus time and temperature.

The 2000 Vac galvanic isolation between inputs, power supply and data line eliminates the effects of all ground loops eventually existing and allows the use of the device in heavy environmental conditions found in industrial applications.

The ECAN 7016 is housed in a rough self-extinguishing plastic enclosure of 22.5 mm thickness, suitable for DIN rail mounting in compliance with the EN 50022 standard .

1.1 Communication protocols

On the ECAN7000 modules the following communication protocol is implemented:

CANopen Protocol: one of the most used standard communication protocol; it allows to interface the modules of ECAN7000 series directly to the CAN Controllers that accept devices in compliance with the CiA DS 301 and CiA DS 401 standards. For communication setting, refer to the User manual.

1.2 Operating instructions

Before to install the device, please read carefully the "Installation instructions" section.

Connect the power supply, the data line and the Input signals as shown in the "Wiring" section.

Refer to the "Led signalling" section to verify the correct working of the device.

To make easy the maintenance or the substitution of the device, it is possible the "hot swap" of the terminals.

2.0 Technical specifications

Typical @ 25 °C and under nominal conditions

Input type	Min	Max		
TC			Input Calibration (1)	
J	-200°C	1200°C	mV, TC	> of ± 0.05 % f.s. or $\pm 5\mu\text{V}$
K	-200°C	1370°C	Input impedance	
S	-50°C	1760°C	TC, mV	$\geq 10 \text{ M}\Omega$
R	-50°C	1760°C	Linearity (1)	
B	400°C	1820°C	TC	± 0.2 % f.s.
E	-200°C	1000°C	Lead wire resistance influence (1)	
T	-200°C	400°C	TC, mV	$\leq 0.8 \text{ }\mu\text{V}/\text{Ohm}$
N	-200°C	1300°C	CJC comp.	$\pm 0.5^\circ\text{C}$
Voltage			Thermal drift (1)	
mV	-50 mV	+50 mV	Full scale	± 0.01 % / °C
mV	-100 mV	+100 mV	CJC	$\pm 0.02^\circ\text{C} / ^\circ\text{C}$
			Sample time	40 ms
			Data Transmission	
			Baud rate	up to 1 Mbps
			Max. Distance	in function of the Baud rate
			Warm-up time	3 min.
Device profile				
In compliance with the CiA DS 301 and CiA DS 401 standard.				
			Power Supply	
			Supply Voltage	10 .. 30 Vdc
			Current consumption	45 mA @ 24 Vdc
			Polarity inversion protection	60 Vdc max
			Isolation Voltage	
				2000 Vac 50 Hz, 1 min. (Inputs/Can Network/Power supply)
			Environmental Conditions	
			Operative Temperature	-10°C .. +60°C
			Storage Temperature	-40°C.. +85°C
			Humidity (not condensed)	0 .. 90 %
			Maximum Altitude	2000 m
			Installation	Indoor
			Category of installation	II
			Pollution Degree	2
			Mechanical specifications	
			Material	Self-extinguish plastic
			IP Code	IP20
			Wiring	wires with diameter 0.8+2.1 mm ² /AWG 14-18
			Tightening Torque	0.8 N m
			Mounting	in compliance with DIN rail standard EN-50022
			Weight	about 150 g.
			EMC (for industrial environments)	
			Immunity	EN 61000-6-2
			Emission	EN 61000-6-4

2.1 Installation instructions

The device ECAN 7016 is suitable to be mounted on DIN rail, in vertical position. For a correct working and a long life of the device, read the following indications.

In case of the devices are mounted side by side, please leave about 5mm between in the following situations:

- Temperature in the cabinet higher than 45 °C and high supply voltage (>27Vdc).

Avoid to place raceways or other objects which could obstruct the ventilation slits. It is suggested to avoid that devices are mounted above appliances generating heat; their ideal place should be in the lower part of the panel.

Avoid to install the devices in a site where vibrations are present. It is recommended to use shielded cable for connecting signals.

The shield must be connected to an earth wire provided for this purpose. Moreover it is suggested to avoid routing conductors near power signal cables.

2.2 Cabling

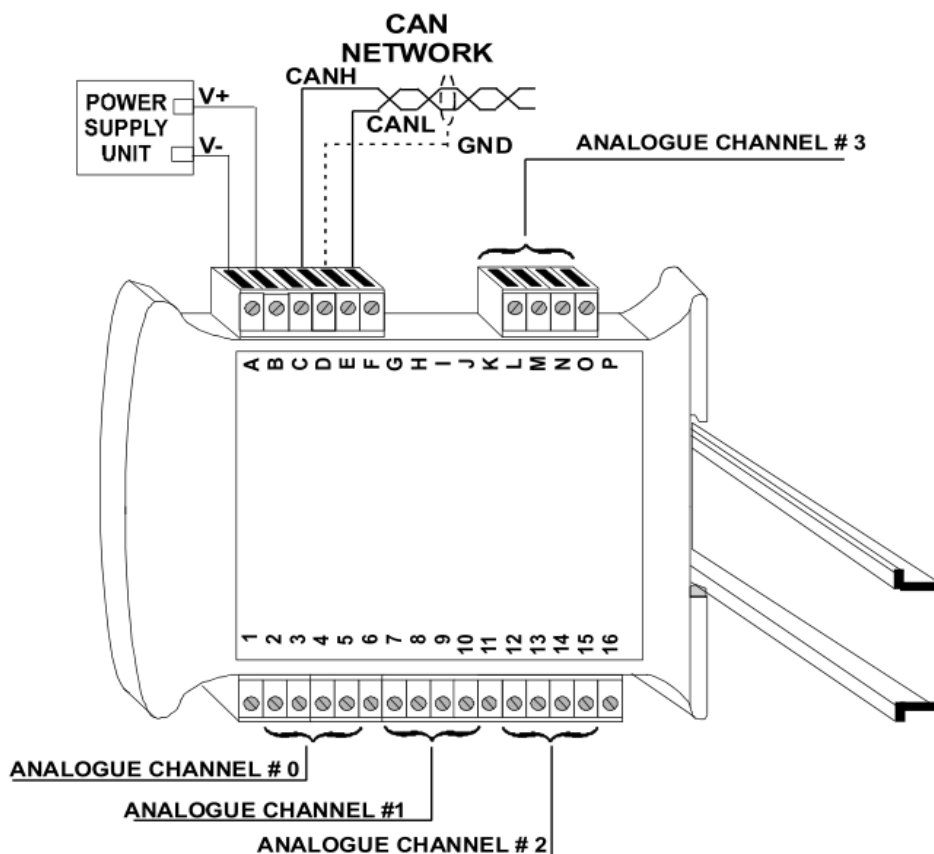

2.3 Wiring

2.3.1 CAN network wiring and power supply wiring

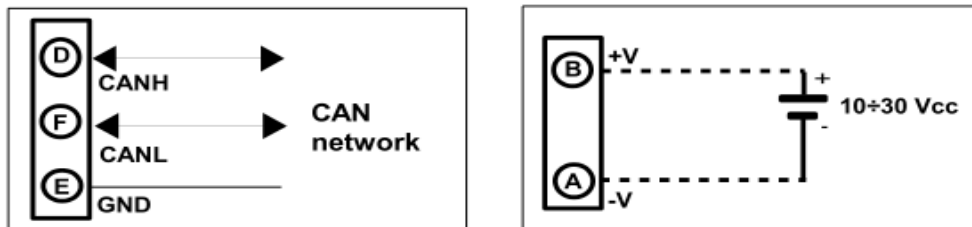

2.3.2 Input wiring

Thermocouple

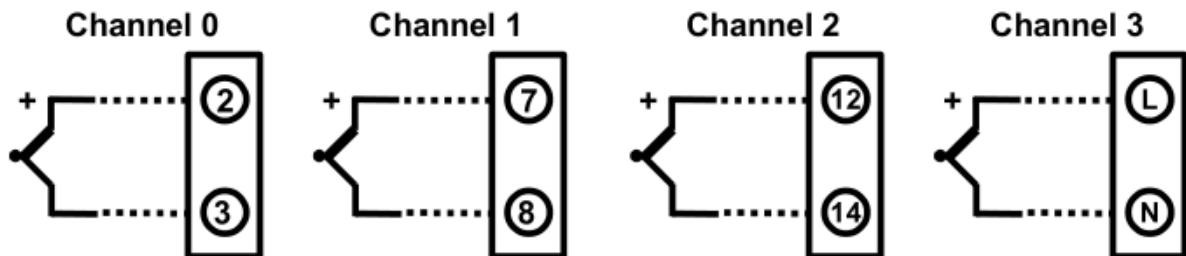

Voltage (mV)

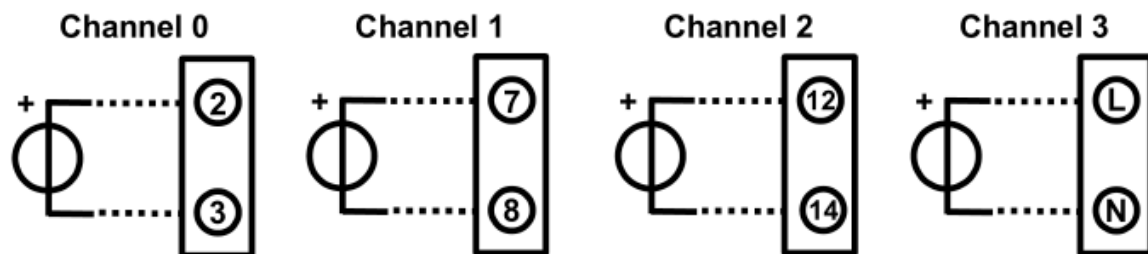

Terminals 3,8,14, and N = input negative reference

NOTES: the input channels are not insulated between them

2.4 DIP – SWITCH

2.4.1 DIP-SWITCH position

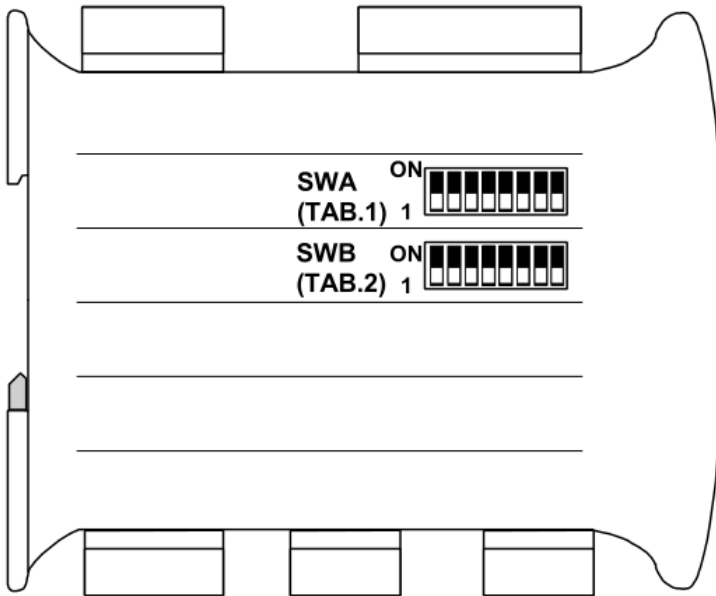

2.4.2 DIP-SWITCH configuration tables

TAB.1 Address setting 1+127
 (Pos.1 LSB; Pos.7 MSB)

SWA							
1	2	3	4	5	6	7	
<input type="checkbox"/>	<input type="checkbox"/>	<input type="checkbox"/>	<input type="checkbox"/>	<input type="checkbox"/>	<input type="checkbox"/>	<input type="checkbox"/>	Addr 1
<input type="checkbox"/>	<input type="checkbox"/>	<input type="checkbox"/>	<input type="checkbox"/>	<input type="checkbox"/>	<input type="checkbox"/>	<input type="checkbox"/>	Addr 2
<input type="checkbox"/>	<input type="checkbox"/>	<input type="checkbox"/>	<input type="checkbox"/>	<input type="checkbox"/>	<input type="checkbox"/>	<input type="checkbox"/>	Addr 3
<input type="checkbox"/>	<input type="checkbox"/>	<input type="checkbox"/>	<input type="checkbox"/>	<input type="checkbox"/>	<input type="checkbox"/>	<input type="checkbox"/>	Addr 4
<input type="checkbox"/>	<input type="checkbox"/>	<input type="checkbox"/>	<input type="checkbox"/>	<input type="checkbox"/>	<input type="checkbox"/>	<input type="checkbox"/>	Addr 5
⋮	⋮	⋮					
<input type="checkbox"/>	<input type="checkbox"/>	<input type="checkbox"/>	<input type="checkbox"/>	<input type="checkbox"/>	<input type="checkbox"/>	<input type="checkbox"/>	Addr 127

TAB.2 Bit rate setting
 (Pos.5 LSB; Pos.8 MSB)

SWB				
5	6	7	8	
<input type="checkbox"/>	<input type="checkbox"/>	<input type="checkbox"/>	<input type="checkbox"/>	10 Kbps
<input type="checkbox"/>	<input type="checkbox"/>	<input type="checkbox"/>	<input type="checkbox"/>	20 Kbps
<input type="checkbox"/>	<input type="checkbox"/>	<input type="checkbox"/>	<input type="checkbox"/>	50 Kbps
<input type="checkbox"/>	<input type="checkbox"/>	<input type="checkbox"/>	<input type="checkbox"/>	125 Kbps
<input type="checkbox"/>	<input type="checkbox"/>	<input type="checkbox"/>	<input type="checkbox"/>	250 Kbps
<input type="checkbox"/>	<input type="checkbox"/>	<input type="checkbox"/>	<input type="checkbox"/>	500 Kbps
<input type="checkbox"/>	<input type="checkbox"/>	<input type="checkbox"/>	<input type="checkbox"/>	800 Kbps
<input type="checkbox"/>	<input type="checkbox"/>	<input type="checkbox"/>	<input type="checkbox"/>	1 Mbps

2.5 LED signalling

LED	COLOR	STATE	DESCRIPTION
RUN	GREEN	ON	Device in Operational mode
		BLINKING	Device in Pre-Operational mode
		SLOW BLINKING	Device stopped
ERR	RED	OFF	No error
		ON	Bus off
		BLINKING	Invalid configuration

2.6 Mechanical dimensions (mm)

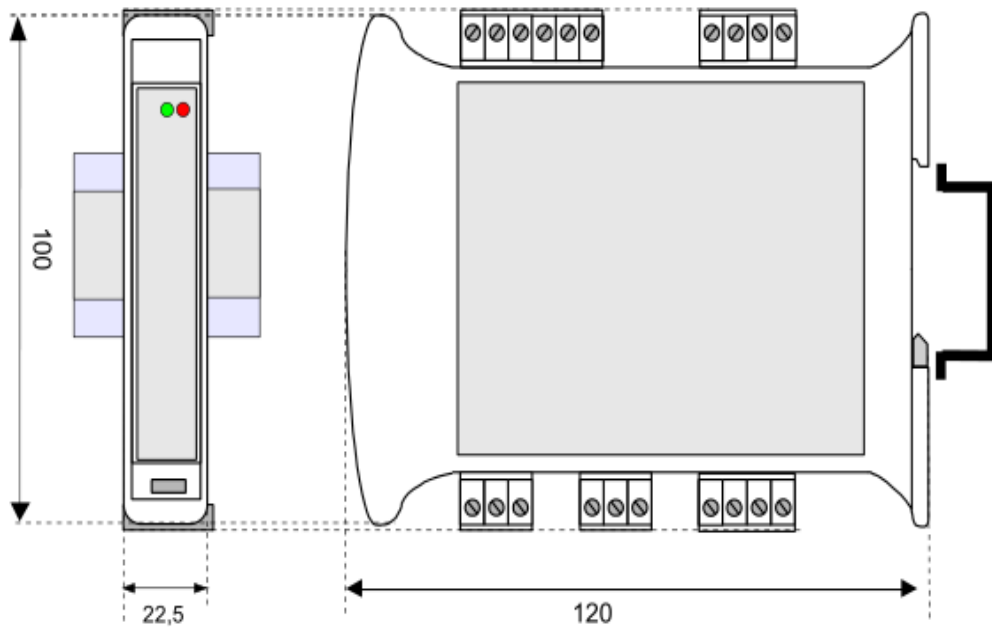

3.0 Profile description

- EDS file:
ECAN7016.eds
- Application layer:
CiA DS 301 Version 4.02
- Device profile:
CiA DS 401 Version 2.1
- Transmit PDO supported :1
- Receive PDO supported : 0

4.0 DIP-SWITCH configuration

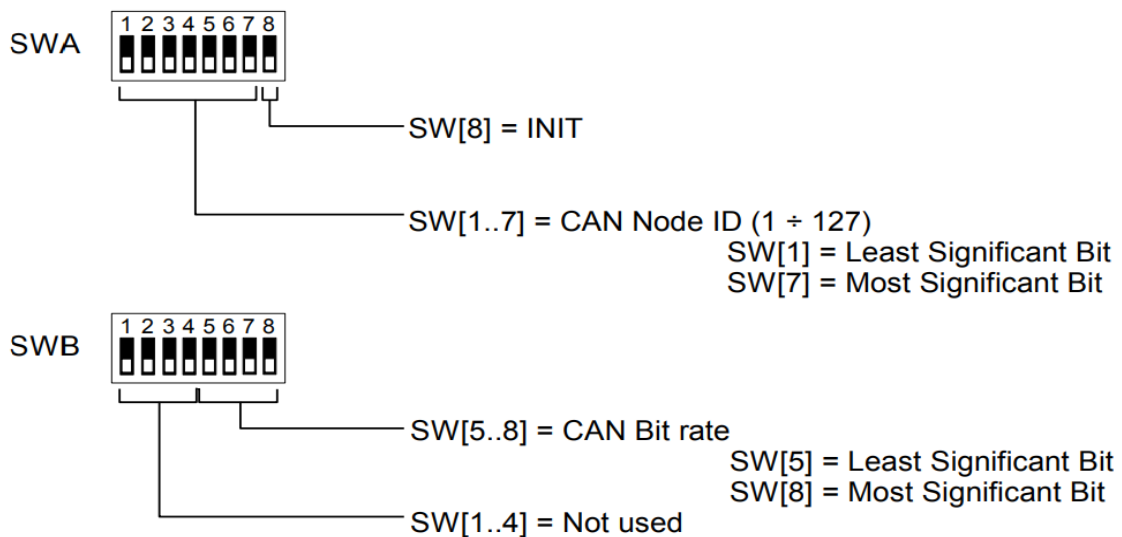

5.0 The object dictionary (OD)

The Object Dictionary is the part of the device profile wherein are grouped the objects that have an influence on the device behaviour (application objects, communication objects and state objects). The structure of the Object Dictionary is predefined as in Draft Standard CiA301. How to read the Object Dictionary table present in this document.

Index	N° Sub-index	Name	Description	Object type	Default value	Access
-------	--------------	------	-------------	-------------	---------------	--------

- Index: 16 bit number expressed in Hex format used to address the object inside the OD;
- Sub-index: 8 bit number expressed in Hex format used to indicate and address the sub parts of an object;
- Name: Defines which is the name of the object inside the OD;
- Description: Text strings that describe what is the function of the object;
- Object type: Indicates what is the data type of the object (Unsigned 32, Boolean, etc..).
- Default value: Indicates what is the default value for an object.
- Access: Indicates what is the type of access designed for an object:
 - RO: indicates an object that could only be read;
 - RW: indicates an object that could be read and written;
 - ---: indicates that the object is a complex object addressed by Sub-index.

6.0 Process data Object (PDO)

The real time data-transfer is performed by means of the Process Data Object (PDO).

The PDO is transmitted only from one Producer to one or more customer; the data capability of a PDO is included between 1 and 8 bytes. There are two kinds of PDOs: the first is used for data transmission (TPDO) and the second is used for data reception (RPDO).

The PDOs are described by the communication parameters and the mapping parameters. The communication parameters define the communication capability of the PDO; the mapping parameters define the content of PDO.

Data type and mapping of the application objects into a PDO is determined by the default structure specified in the Object Dictionary.

The communication parameter is composed of:

- COB-ID;
- Transmission type;
- Inhibit time;
- Event timer;

6.1 COB-ID

The COB-ID is the Connection Object Identifier and contains the unique CAN message Identifier of the object and additional configuration bits. For the PDOs the following 32 bit COB-ID are foreseen.

TPDO1: NODO ID + 0x00000180;
TPDO2: NODO ID + 0x00000280;
TPDO3: NODO ID + 0x00000380;
TPDO4: NODO ID + 0x00000480;
RPDO1: NODO ID + 0x00000200;
RPDO2: NODO ID + 0x00000300;
RPDO3: NODO ID + 0x00000400;
RPDO4: NODO ID + 0x00000500.

The NODE ID is the CAN node ID of the device. The range value is from 0x01 (decimal 1) up to 0x7F (decimal 127). If the first byte is 8 the PDO is not used; if it is 0, the PDO is used.

6.2 Transmission type

To transmit the PDO the following transmission modes can be used:

- Synchronous Transmission
- Asynchronous Transmission

The value of the parameter "Transmission type" defines how the PDO transmission is performed.

TPDO:

- Value **0**.
The TPDO is synchronous acyclic; it is transmitted after the receiving of a SYNC object when one or more parameters change.
- Value **1-240**.
The TPDO is synchronous cyclic. It is transmitted after every nth SYNC object within the "Synchronous Window Length" (object 0x1007). The value n is the value of the Transmission Type. **NOTE:** The Communication Cycle Period object (0x1006) express the time between two SYNC and must have the same value or a bigger value of the Synchronous Window Length.
- Value **255**.
The TPDO is asynchronous and it is transmitted in function of the parameter "Event timer".

RPDO:

- Value **0-240**.
The RPDO is synchronous and the actual value of transmission type is not relevant because the RPDO is processed on reception of the next SYNC object.
- Value **255**.
The RPDO is asynchronous and it is processed by the node as soon as the PDO arrives.

Elco Elettronica Snc, Via della Costituzione, 50 42015 – Correggio (RE)
Tel: +39 0522 691024 / +39 0522 631753
Fax: +39 0522 691322
Website: www.elcoelettronica.it



6.3 Inhibit time

This is the time within the PDO is not transmitted. The PDO is transmitted only when the time expires.

6.4 Event Timer

The PDO is transmitted on a fixed time base.

7.0 Functional diagram for analogue inputs transmission

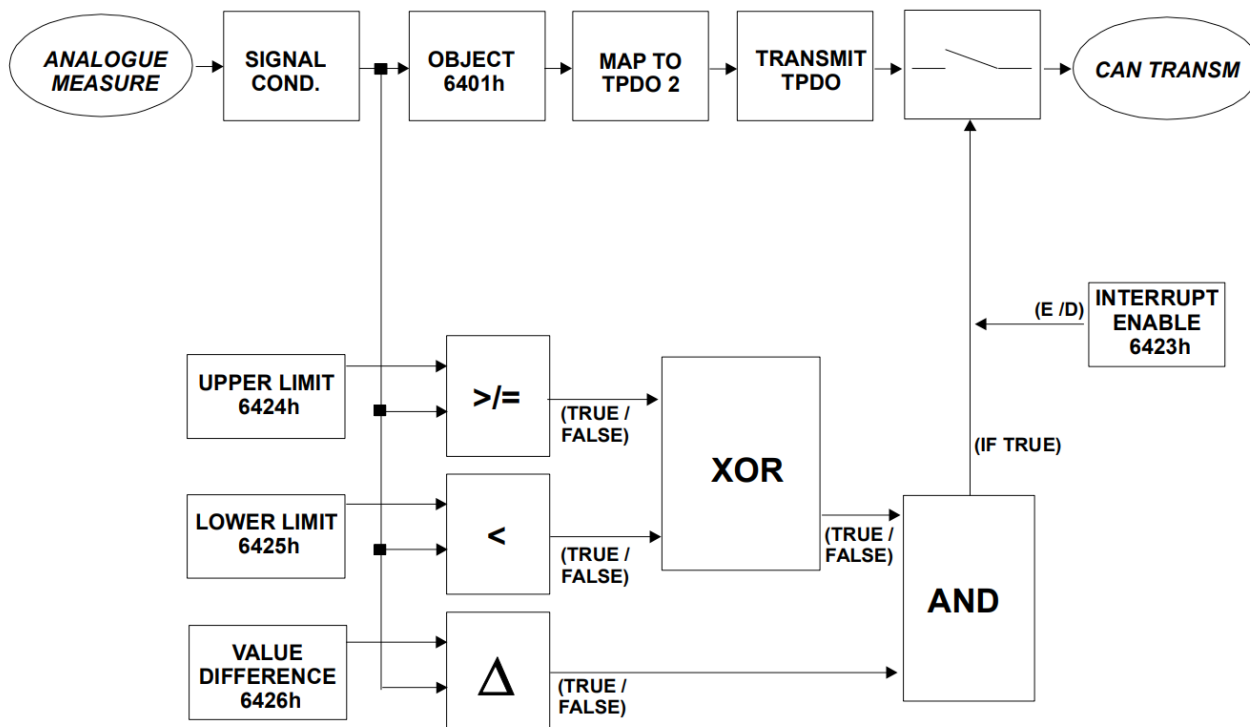

7.1 Interrupt triggering TPDO transmission

The analogue signals are processed and transferred to the object 6401h.

The data of this object are moved to the TPDO in function of the mapping parameters set in the object 1A01h. The communication parameters of TPDO are defined in the object 1801h .

In the same time the analogue measure is checked with the values contained in the objects 6424h (upper limit), 6425h (lower limit) and 6426h (delta). The system execute the boolean operation XOR between the object 6424h (true if the input measure is greater or equal the pre-set values of the object) and the object 6425h (true if the input measure is lower the pre-set values of the object) and successively execute the boolean operation AND between the result of the XOR and the object 6426h (true if the input measure rises or falls above or below of the delta value respect to the last communicated value).

If the result of the operation AND is true, the transmission of the TPDO is performed only if the object 6423h has been enabled (value set as 255).

8.0 Set the operative state at the device's startup

Follow the next procedure to set-up the device's operative state at the startup (Operational or Pre-Operational).

8.1 “Operational” state setting

1. Write the decimal value 0 (0x00) in the object 1F80h (NMT startup).
2. Execute the command “Save all parameters” as described in the object 1010h.
3. Execute the command “Restore all parameters” as described in the object 1011h.
4. Power-off and then power-on again the device.
5. After this operation the device will always start in Operational.

8.2 “Pre-Operational” state setting

1. Write the decimal value 4 (0x04) in the object 1F80h (NMT startup).
2. Execute the command “Save all parameters” as described in the object 1010h.
3. Execute the command “Restore all parameters” as described in the object 1011h.
4. Power-off and then power-on again the device.
5. After this operation the device will always start in Pre-Operational.

As default the device starts up in “Operational”.

9.0 Object dictionary (OD)

Index	N° Sub-index	Name	Description	Object type	Default value	Access
0x1000	0	Device Type	Identifies the type of device (analog input) and its Device Profile (CiA 401)	Unsigned 32	0x00040191	RO
0x1001	0	Error register	Register used to monitor eventual internal errors	Unsigned 8	0x00	RO
0x1002	0	Manufacturers status register	Status register	Unsigned 32	0x00000000	RO
0x1003	2	Predefined error field	Contains the list of the recent errors	Array	-----	----
	Sub Index 0	Number of errors	Contains the number of errors occurred	Unsigned 8	0x00	RW
	Sub Index 1	Standard error field 1	Stores the recent errors occurred	Unsigned 32	0x00000000	RO
0x1005	0	SYNC COB-ID	Defines the COB-ID of the Synchronism Object consumed	Unsigned 32	0x00000080	RW
0x1006	0	Communication cycle period	Defines the SYNC interval and it is expressed as μ s	Unsigned 32	0x00000000	RW
0x1007	0	Synchronous window length	Defines the time window expressed as μ s to transmit the synchronous PDO after the SYNC object	Unsigned 32	0x00000000	RW
0x1008	0	Manufacturer device name	Contains the device's name	Visible String	"ECAN 7016"	RO
0x1009	0	Manufacturer hardware Version	Indicates the hardware version of the device	Visible String	"1.00"	RO
0x100A	0	Manufacturer software Version	Indicates the version of the device's firmware	Visible String	"2.10"	RO
0x1010	2	Store parameters	Supports the saving of the parameters	Array	-----	----
	Sub Index 0	Maxsub-index number	Contains the number of sub index supported	Unsigned 8	0x01	RO
	Sub Index 1	Save all parameters	Saves all the parameters	Unsigned 32	0x00000000	RW
Write the value 65766173 Hex, 1702257011 Decimal (ASCII "save") in sub-index to save data.						
0x1011	2	Restore default	Restore the default values of the parameters	Array	-----	----
	Sub Index 0	Max sub-index number	Contains the number of sub index supported	Unsigned 8	0x01	RO
	Sub Index 1	Restore all parameters	Restores all the parameters	Unsigned 32	0x00000000	RW
Write the value 64616F6C Hex, 1684107116 Decimal (ASCII "load") in sub-index to restore data. Type of reset caused at the restore of default: - restore of sub index 1 : Node reset						

Index	N° Sub-index	Name	Description	Object type	Default value	Access
0x1014	0	COB-ID Emergency Object (EMCY)	Defines the COB-ID of the Emergency Object	Unsigned 32	Nodo ID + 0x80	RW
0x1015	0	Inhibit time (EMCY)	Defines the inhibit time for the Emergency Object (multiple of 100 µs)	Unsigned 32	0x00000000	RW
0x1016	2	Consumer heartbeat time	Defines the heartbeat cycle time (multiple of 1 ms)	Array	-----	----
	Sub Index 0	Max sub-index number	Contains the number of sub index supported	Unsigned 8	0x01	RO
	Sub Index 1	Consumer heartbeat time	Heartbeat time	Unsigned 32	0x00000000	RW
0x1017	0	Producer heartbeat time	Defines the heartbeat cycle time (multiple of 1 ms)	Unsigned 16	0x00000000	RW
0x1018	5	Identity	Contains the general information about the device	Record	-----	----
	Sub Index 0	Max sub-index number	Contains the number of sub index supported	Unsigned 8	0x04	RO
	Sub Index 1	Vendor ID	Unique code manufacturer	Unsigned 32	0x000003CD	RO
	Sub Index 2	Product code	ECAN7016 ID code	Unsigned 32	0x00000004	RO
	Sub Index 3	Revision number	Revision number	Unsigned 32	0x00000000	RO
	Sub Index 4	Serial number	Serial number code	Unsigned 32	0x00000000	RO
0x1029	2	Error behaviour	Defines the behaviour of the device in case of error encountered	Array	-----	----
	Sub Index 0	Max sub-index number	Contains the number of error classes	Unsigned 8	0x01	RO
	Sub Index 1	Communication error	Defines the device condition for a communication error	Unsigned 8	0x00	RW
0x1200	3	Server SDO parameters	Describes the SDO communication channel for the node	Array	-----	----
	Sub Index 0	Max sub-index number	Contains the number of sub-index supported	Unsigned 8	0x02	RO
	Sub Index 1	COB ID Client to Server (Receive SDO)	Defines the COB ID in case of receiving SDO	Unsigned 32	Nodo ID + 0x600	RO
	Sub Index 2	COB ID Server to Client (Transmit SDO)	Defines the COB ID in case of transmitting SDO	Unsigned 32	Nodo ID + 0x580	RO

Index	N° Sub-index	Name	Description	Object type	Default value	Access																											
0x1801	5	2°TDO communication parameters	List of the parameters of the 2 nd TPDO	Record	-----	----																											
	Sub Index 0	Max sub-index number	Contains the number of sub-index supported	Unsigned 8	0x04	RO																											
	Sub Index 1	COB ID	Defines the COB ID of the PDO	Unsigned 32	Nodo ID + 0x280	RW																											
	Sub Index 2	Transmission type	Defines the transmission type for the TPDO	Unsigned 8	0xFF	RW																											
	Sub Index 3	Inhibit timer	Defines the delay to transmit the next PDO (multiple of 100 µs)	Unsigned 16	0x0000	RW																											
	Sub Index 5	Event timer	Transmits the PDO when the timer is expired (multiple of 1 ms)	Unsigned 16	0x0000	RW																											
0x1A01	5	2 nd TPDO mapping parameters	List of mapping parameters of the 2 nd TPDO	Array	-----	----																											
	Sub Index 0	Max sub-index number	Contains the number of sub-index supported	Unsigned 8	0x04	RW																											
	Sub Index 1	Mapped Object 1	Defines the 1 st object mapped into TPDO	Unsigned 32	0x64010110	RW																											
	Sub Index 2	Mapped Object 2	Defines the 2 nd object mapped into TPDO	Unsigned 32	0x64010210	RW																											
	Sub Index 3	Mapped Object 3	Defines the 3 rd object mapped into TPDO	Unsigned 32	0x64010310	RW																											
	Sub Index 4	Mapped Object 4	Defines the 4 th object mapped into TPDO	Unsigned 32	0x64010410	RW																											
0x1F80	0	NMT Startup	Defines the operative state of the device at the startup	Unsigned 32	0x00000000	RW																											
	Value available: Dec. 0 = Device in Operational. Dec. 4 = Device in Pre-Operational																																
0x2101	0	Can Node ID	Defines which is the default CAN node number of the device	Unsigned 8	0x7F	RO																											
Values available: from Dec.1 (0x01) up to Dec 127 (0x7F).																																	
0x2102	0	Can bit rate	Defines which is the default bit rate value	Unsigned 8	0x03	RO																											
	Decimal and Hex value to select the Bit rate parameter.																																
	<table border="1"> <thead> <tr> <th>Bit rate</th> <th>Value (Dec)</th> <th>Value (Hex)</th> </tr> </thead> <tbody> <tr> <td>10 Kbps</td> <td>0</td> <td>0x00</td> </tr> <tr> <td>20 Kbps</td> <td>1</td> <td>0x01</td> </tr> <tr> <td>50 Kbps</td> <td>2</td> <td>0x02</td> </tr> <tr> <td>125 Kbps</td> <td>3</td> <td>0x03</td> </tr> <tr> <td>250 Kbps</td> <td>4</td> <td>0x04</td> </tr> <tr> <td>500 Kbps</td> <td>5</td> <td>0x05</td> </tr> <tr> <td>800 Kbps</td> <td>6</td> <td>0x06</td> </tr> <tr> <td>1 Mbps</td> <td>7</td> <td>0x07</td> </tr> </tbody> </table>						Bit rate	Value (Dec)	Value (Hex)	10 Kbps	0	0x00	20 Kbps	1	0x01	50 Kbps	2	0x02	125 Kbps	3	0x03	250 Kbps	4	0x04	500 Kbps	5	0x05	800 Kbps	6	0x06	1 Mbps	7	0x07
	Bit rate	Value (Dec)	Value (Hex)																														
	10 Kbps	0	0x00																														
	20 Kbps	1	0x01																														
	50 Kbps	2	0x02																														
	125 Kbps	3	0x03																														
	250 Kbps	4	0x04																														
	500 Kbps	5	0x05																														
800 Kbps	6	0x06																															
1 Mbps	7	0x07																															

Index	N° Sub-index	Name	Description	Object type	Default value	Access																																	
0x2107	5	Sensor type selection	Contains the programming of the Analog Input Channels	Array	-----	---																																	
	Sub Index 0	Max sub-index number	Contains the number of sub-index supported	Unsigned 8	0x04	RO																																	
	Sub Index 1	CH1 sensor type	Programming of Input Channel 1	Unsigned 8	0x01	RW																																	
	Sub Index 2	CH2 sensor type	Programming of Input Channel 2	Unsigned 8	0x01	RW																																	
	Sub Index 3	CH3 sensor type	Programming of Input Channel 3	Unsigned 8	0x01	RW																																	
	Sub Index 4	CH4 sensor type	Programming of Input Channel 4	Unsigned 8	0x01	RW																																	
Decimal and Hex values to select the type of the input sensor.																																							
<table border="1"> <thead> <tr> <th>Input type</th> <th>Value (Dec)</th> <th>Value (Hex)</th> </tr> </thead> <tbody> <tr> <td>Input not used</td> <td>0</td> <td>0x00</td> </tr> <tr> <td>± 100 mV</td> <td>1</td> <td>0x01</td> </tr> <tr> <td>Thermocouple J</td> <td>24</td> <td>0x18</td> </tr> <tr> <td>Thermocouple K</td> <td>25</td> <td>0x19</td> </tr> <tr> <td>Thermocouple T</td> <td>26</td> <td>0x1A</td> </tr> <tr> <td>Thermocouple E</td> <td>27</td> <td>0x1B</td> </tr> <tr> <td>Thermocouple R</td> <td>28</td> <td>0x1C</td> </tr> <tr> <td>Thermocouple S</td> <td>29</td> <td>0x1D</td> </tr> <tr> <td>Thermocouple B</td> <td>30</td> <td>0x1E</td> </tr> <tr> <td>Thermocouple N</td> <td>31</td> <td>0x1F</td> </tr> </tbody> </table>							Input type	Value (Dec)	Value (Hex)	Input not used	0	0x00	± 100 mV	1	0x01	Thermocouple J	24	0x18	Thermocouple K	25	0x19	Thermocouple T	26	0x1A	Thermocouple E	27	0x1B	Thermocouple R	28	0x1C	Thermocouple S	29	0x1D	Thermocouple B	30	0x1E	Thermocouple N	31	0x1F
Input type	Value (Dec)	Value (Hex)																																					
Input not used	0	0x00																																					
± 100 mV	1	0x01																																					
Thermocouple J	24	0x18																																					
Thermocouple K	25	0x19																																					
Thermocouple T	26	0x1A																																					
Thermocouple E	27	0x1B																																					
Thermocouple R	28	0x1C																																					
Thermocouple S	29	0x1D																																					
Thermocouple B	30	0x1E																																					
Thermocouple N	31	0x1F																																					
Voltage: values expressed in tens of uV Thermocouples: values expressed in tenths of °C																																							

Index	N° Sub-index	Name	Description	Object type	Default value	Access
0x6401	5	16 bit Input Channel Measure	Contains the measures of the Analog Input Channels	Array	-----	----
	Sub Index 0	Max sub-index number	Contains the number of sub-index supported	Unsigned 8	0x04	RO
	Sub Index 1	CH1 measure	Shows the measure of the Input Channel 1	Integer 16	-----	RO
	Sub Index 2	CH2 measure	Shows the measure of the Input Channel 2	Integer 16	-----	RO
	Sub Index 3	CH3 measure	Shows the measure of the Input Channel 3	Integer 16	-----	RO
	Sub Index 5	CH4 measure	Shows the measure of the Input Channel 4	Integer 16	-----	RO
0x6423	0	16 bits Analogue Global Interrupt Enable	Enables / Disable globally the interrupt behaviour	Unsigned 8	0	RW
	Value 0: object disable (no analog input activates the interrupt). Value 255: object enabled (one or more analog input can activate the interrupt).					
0x6424	5	16 bits Analogue Interrupt Upper limits	Contains the upper limits for the analog input channels	Array	-----	----
	Sub Index 0	Max sub-index numbe	Contains the number of sub-index supported	Unsigned 8	0x04	RO
	Sub Index 1	CH1 Interrupt Upper limit	Upper limit of the Channel 1	Integer 16	0x0000	RW
	Sub Index 2	CH2 Interrupt Upper limit	Upper limit of the Channel 2	Integer 16	0x0000	RW
	Sub Index 3	CH3 Interrupt Upper limit	Upper limit of the Channel 3	Integer 16	0x0000	RW
	Sub Index 4	CH4 Interrupt Upper limit	Upper limit of the Channell 4	Integer 16	0x0000	RW
	This object works only if the Object 0x6423 has been enabled. The interrupt is triggered when the input measure rise above or is equal to the settetd value.					
0x6425	5	16 bits Analogue Interrupt Lower limits	Contains the lower limits for the analog input channels	Array	-----	----
	Sub Index 0	Max sub-index number	Contains the number of sub-index supported	Unsigned 8	0x04	RO
	Sub Index 1	CH1 Interrupt Lower limit	Lower limit of the Channel 1	Integer 16	0x0000	RW
	Sub Index 2	CH2 Interrupt Lower limit	Lower limit of the Channel 2	Integer 16	0x0000	RW
	Sub Index 3	CH3 Interrupt Lower limit	Lower limit of the Channel 3	Integer 16	0x0000	RW
	Sub Index 4	CH4 Interrupt Lower limit	Lower limit of the Channel 4	Integer 16	0x0000	RW
	This object works only if the Object 0x6423 has been enabled. The interrupt is triggered when the input measure falls below the settetd value.					

Index	N° Sub-index	Name	Description	Object type	Default value	Access
0x6426	5	16 bits Analogue Interrupt Delta	Contains the delta values for the analog input channels	Array	-----	----
	Sub Index 0	Max sub-index number	Contains the number of sub-index supported	Unsigned 8	0x04	RO
	Sub Index 1	CH1 Delta limit	Delta value for the Channel 1	Integer 16	0x000A	RW
	Sub Index 2	CH2 Delta limit	Delta value for the Channel 2	Integer 16	0x000A	RW
	Sub Index 3	CH3 Delta limit	Delta value for the Channel 3	Integer 16	0x000A	RW
	Sub Index 4	CH4 Delta limit	Delta value for the Channel 4	Integer 16	0x000A	RW
This object works only if the Object 0x6423 has been enabled. The interrupt is triggered when the input rises or falling above or below the last communicated value.						